

Type description for retractable supply post MS SE 30AN Standard

Technical data

Degree of protection:	IP 44 for electrical sockets, on request up to IP67 IP 65 for distributors
Protection equipment:	earth conductor class 1
Nominal voltage / frequency:	230/400V, 50 Hz
Kind of voltage:	TN-S system
Connection value:	approx. 15 kW
Supply cable max. permissible:	5 x 6 mm ²

Equipment side A

1 x distributor, 10 partitions
1 x elcb 40/0,03A, 4-pole
1 x mcb 16 A, B, 3-pole
2 x mcb 16 A, B, 1-pole
1 x mcb 2 A, C, 1-pole (for heating)

Equipment side B

1 x CEE 16 A, 5-pole
2 pieces of isolated ground receptacles

Weights

Concrete shaft + shaft insert:	200 kg
Device column equipped:	30 kg

Dimensions

Concrete shaft (HxWxD):	410 x 570 x 570 mm
Cover support (incl. sealing compound):	110 mm
Installation depth:	520 mm
Extendible height:	233 mm
Space for pavement in cover:	50 mm
Load capacity for the paved cover under DIN EN 124:	D 400, 40t point load
Lifting mechanism:	Threaded spindle
Sewage connections:	2 x DN 40

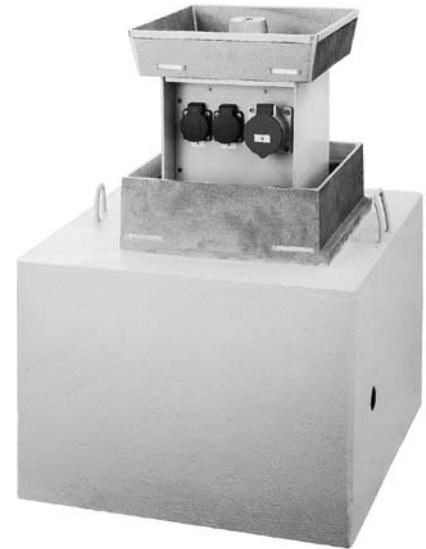

Order-No.:

MS SE 30AN-Sta-01

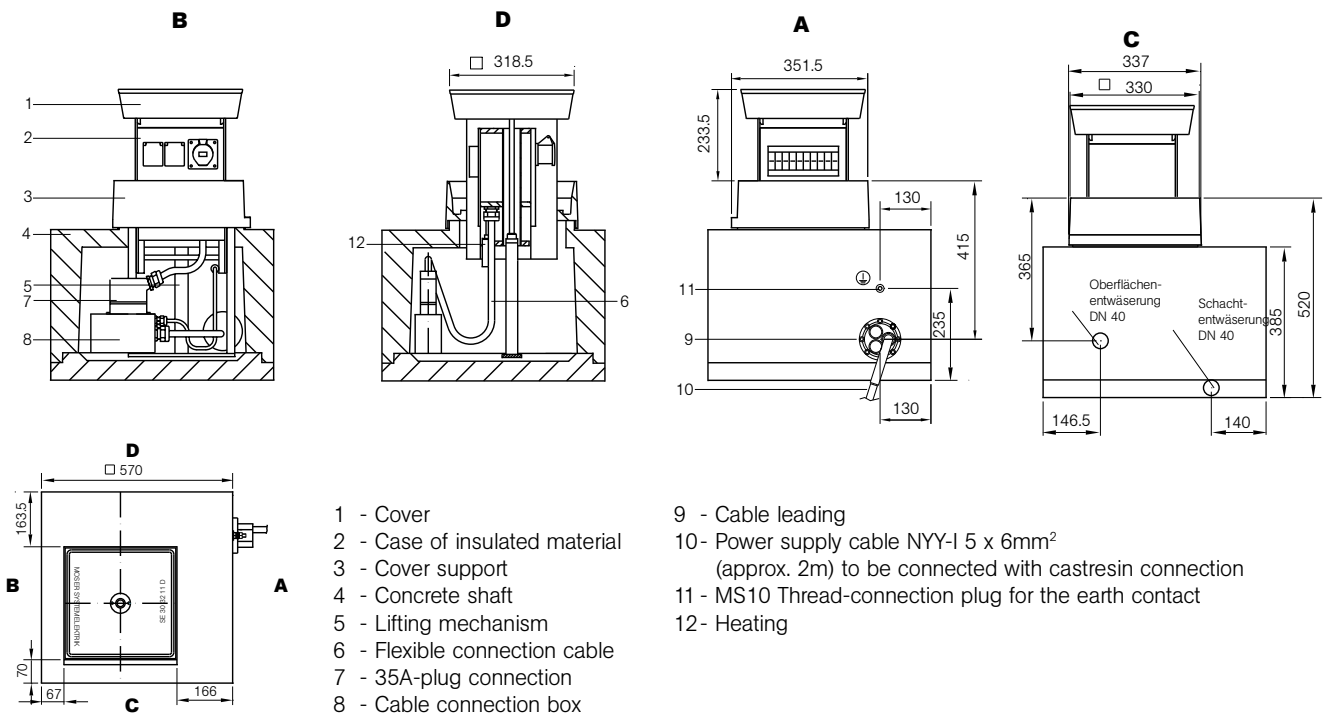

Submission text for retractable supply post MS SE 30AN Standard

Retractable, procticable, column for connection and distribution of electricity as per the VDE-regulations for open space, soil flushing installation.
Load capacity of the paved cover under the provisions of DIN EN 124 - D 400 (40t point load),
kind of protection IP 44 for electrical sockets, on request up to IP 67
kind of protection IP 65 for distributors,

consisting of:

Concrete shaft

Supporting concrete shaft under the provisions of DIN 1045 - B 35
(for traffic loads under the provisions of DIN 1072, bridge class SLW 60)
for a protected insertion of the retractable supply post into soil.

There are integrated:

- Cable connection box for the assembly of a connecting module
- C-rail for tension relief of the connection cable.
- Thread-connection plug for the installation of the exterior earth contact.
- Surface water drainage DN 40.
- Shaft drainage DN 40.

Shift insertion

System-oriented, metal insertion of corrosion resistant aluminium
consisting of:

- Guide frame (corrosion resistant aluminium profiles) as sliding supports for the device column.
- Cover support with sealing, pavement frame, drainage, open pipe for surface water drainage.
- Bottom support with lifting mechanism (threaded-spindle, spindle-guide and spindle nut).

Device column

Extendable, horizontal case construction of weather resistant PVC with
built on shift cover of cast aluminium, built-in space of 50 mm for pavement.

The case of insulated material (IP 55) is a self supporting construction and
constructed as a rugged and shock resistant device.

2 sides (A+B) are provided for the equipment of the device.

Lead-in can be plugged by flexible connection cable 5 x 16 mm² .

The Lifting mechanism with threaded spindle is located in the centre of the device column.

Water-tight opening of spindle drive through the lid.

Self-regulating heating in the electrical operating room to protect from frost damage and condensation.

Electric device modules

The interior wiring of the devices and the feeding-in are arranged for the TN-S system (as per diagram of connections).
Wiring for other systems only after technical clarification and written contract.

Side A:

1 piece of distribution module with transparent cover for 12 partitions
1 piece of elcb 40 A, 4-pole, 30 mA
1 piece of mcb 16A, B, 3-pole
2 pieces of mcb 16A, B, 1-pole
1 piece of mcb 2A, C, 1-pole

Side B:

1 piece of attached electrical outlet CEE 16 A, 5-pole
2 pieces of isolated ground receptacles

Cable connection box

Cable connection box with 35A-plug-connector incl. lead in cable, approx. 2m, watertight lead through the concrete shaft.

Crank handle

(included in price when ordered)

Price: per piece + VAT

Delivery: assembled completely, completely wired and checked according to VDE 0100 part 610 including electric plans and installation instructions.
ex factory, packaging not included

Delivery time: min. 4-6 weeks after receipt of order and technical clarification.

Survey of diagram of connections for retractable supply post MS SE 30AN Standard

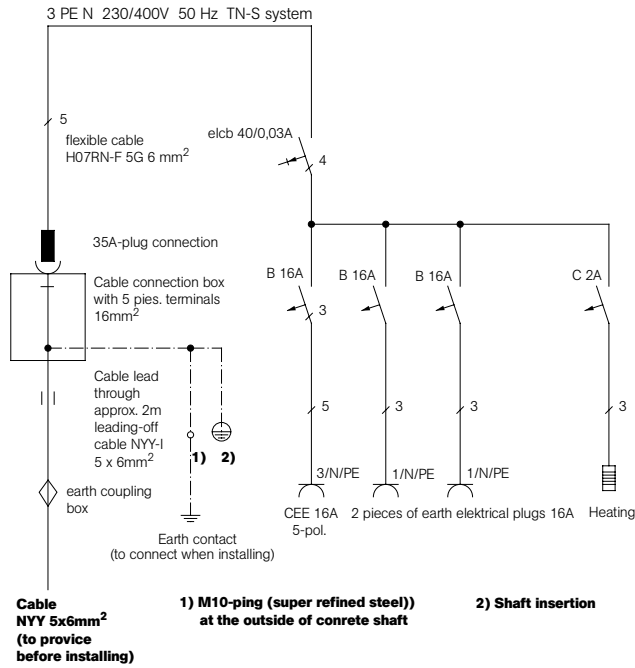

Submitted by:

TB SE 30AN Standard- E - 07/2011
 Technical alterations are subject to change without prior notice.
 Our terms of delivery and payment are in validity.

MOSER SYSTEMELEKTRIK
 Erikaweg 1
 D-78141 Schönwald
 Telefon 0049(0)77 22/96 97-0
 Telefax 0049(0)77 22/96 97-11
 info@moser-systemelektrik.de
 www.moser-systemelektrik.de